

STANDARD PLANTS

FULLY-PACKAGED
MODULAR SOLUTIONS



Air Liquide Group

The world leader in gases, technologies and services for Industry and Health

Air Liquide is present in 80 countries with approximately 65,000 employees and serves more than 3 million customers and patients. Oxygen, nitrogen and hydrogen are essential small molecules for life, matter and energy. They embody Air Liquide's scientific territory and have been at the core of the company's activities since its creation in 1902.

Air Liquide's ambition is to lead its industry, deliver long term performance and contribute to sustainability.

Air Liquide Engineering & Construction

A technology partner of choice

Air Liquide Engineering & Construction builds the Group's production units (mainly air gas separation and hydrogen production units) and provides external customers with efficient, sustainable, customized technology and process solutions.

Our core expertise in industrial gas, energy conversion and gas purification, enables customers to optimize natural resources.

We cover the entire project life-cycle:

license engineering services / proprietary equipment, high-end engineering & design capabilities, project management & execution services. In addition we also offer efficient customer services through our worldwide set-up.

As a technology partner, customers benefit from our research and development to achieve energy transition goals.

Our full suite of technologies

- Liquefied Natural Gas
- Cryogenics
- Hydrogen
- Syngas
- Petrochemicals
- Natural Gas Treatment
- Sulfur
- **Standard Plants**
- Oleochemicals

15

Engineering centers and front end offices

3

Manufacturing centers

60

Proprietary technologies

1,600

Patents

Standard Plants

Fully-packaged modular solutions for a range of industrial applications

You benefit from our broad expertise, rooted in more than 20 years of operating and maintenance experience worldwide.

These Standard Plants are fully-packaged and pre-tested skidded units, designed to be quickly and easily integrated into either existing or planned industrial facilities.

Standard Plants minimize your construction and start-up costs, and are made for short time to production. They are safe, reliable, simple to operate, and easy to maintain.

We design and develop these standardized units for the Air Liquide Group in a broad range of industries, as well as for third-party customers.



Pulp and paper

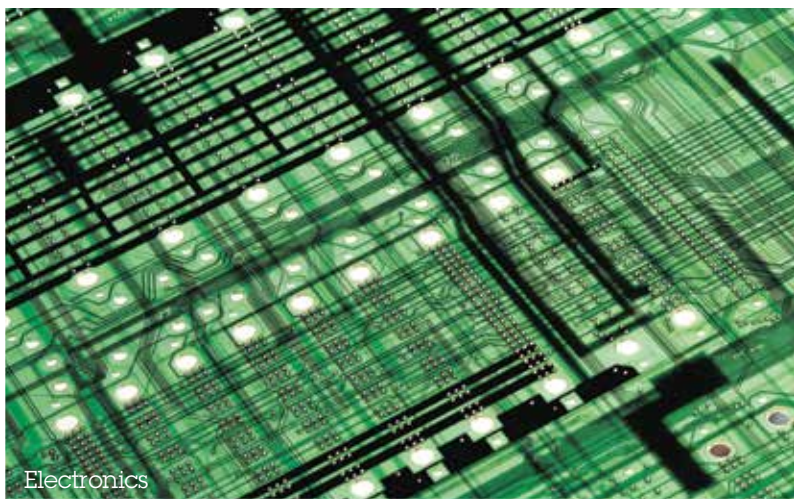

Electronics



Steelmaking



Refineries

Oxygen generator

VSA Systems

Vacuum Swing Adsorption Unit

On-demand oxygen generator

Drawing on Air Liquide's long experience in oxygen production, our Vacuum Swing Adsorption (VSA) oxygen generation unit uses the process of air separation by adsorption. This process uses specific zeolite adsorbents for the selective adsorption of nitrogen over oxygen and argon.

Compact unit, ready to install

Built and delivered as a fully-packaged and pre-tested skid, our VSA units can be directly incorporated into industrial facilities. This minimizes the time required for installation and start-up, and optimizes your overall implementation schedule. The VSA system is simple to operate, as it is designed to run automatically and unattended.

Typical applications

Installed in plants in the steel, glass, pulp and paper, wastewater treatment, and mining industries.

Advantages

- Compact design
- Fully packaged and pre-tested skid
- Quick set-up time and short start-up period
- Automatic start, stop and load adaptation allows system to run unattended
- Safe, reliable, simple to operate, easy to maintain

Specifications

- **Plant type:** Skid manufactured unit
- **Production capacity:** 40 to 150 tons per day of gaseous oxygen
- **Purity:** 90% to 93% oxygen
- **Pressure:** up to 40 barg with O₂ compression
- **Specific energy:** 265 kilowatt hours per ton (kWh/t)
- **References:** more than 100 units in operation worldwide

VSA oxygen generation systems

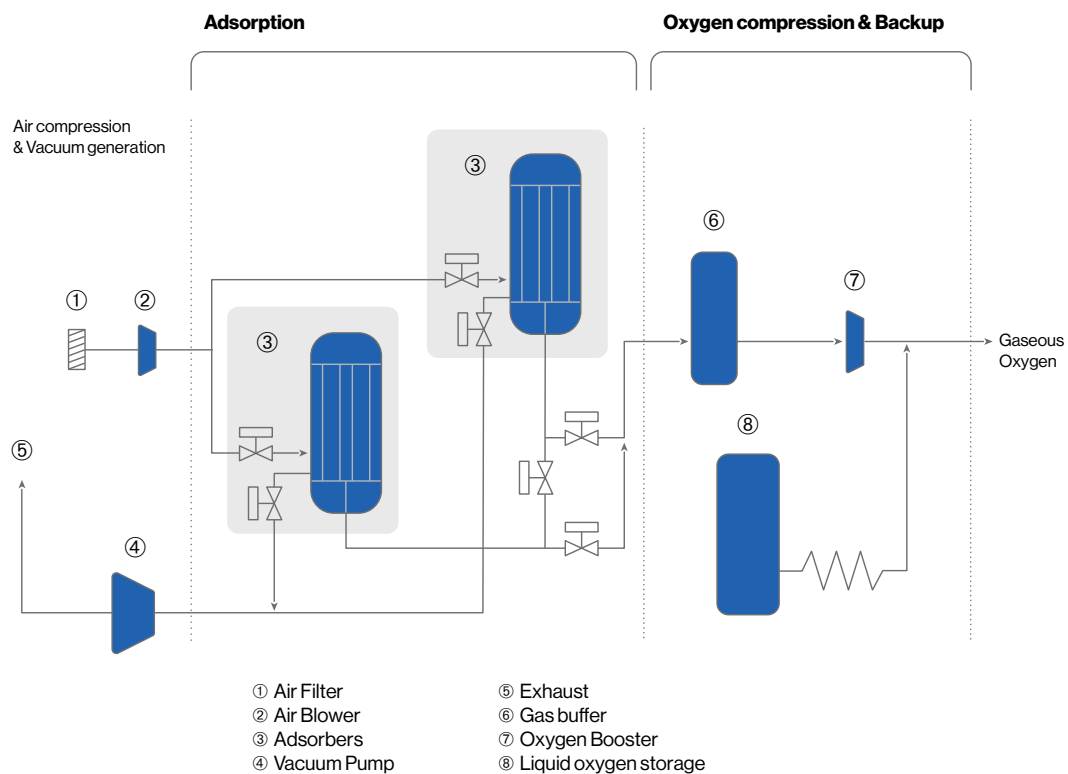

Oxygen generator

SIGMA

Standard Air Separation Unit

Oxygen generator using the latest separation technology

The SIGMA standard air separation unit is based on the latest technology in this field, using air compression, adsorption, purification, cryogenic distillation of main components, and internal compression.

It produces oxygen up to 99.6% purity. Available co-products include gaseous nitrogen, liquid oxygen, nitrogen and argon to refill backup liquid tanks.

Cost-efficient and flexible

The fully-packaged SIGMA unit helps reduce both your construction costs and time to production. Depending on customer requirements, the unit can be configured to optimize capital expenditures (CAPEX) and/or operational expenditures (OPEX).

Typical applications

Installed in plants in the steel (e.g. oxygen boosting, electric arc furnace), chemicals (e.g. ethylene oxide), glass, non-ferrous metals, pulp and paper, and wastewater treatment industries.

Advantages

- Reduction of construction costs and time to production
- Configured for CAPEX and/or OPEX
- Co-product availability:
 - Liquid nitrogen
 - Liquid oxygen
 - Gaseous nitrogen
 - Liquid argon
 - Compressed dry air
- Safe, reliable, simple to operate, easy to maintain

Specifications

- **Plant type:** Skid manufactured unit
- **Production capacity:** 110 to 350 tons per day of oxygen
- **Purity:** 96% to 99.6% oxygen
- **Pressure:** Up to 40 barg
- **Specific energy:** 280 to 460 kilowatt hours per ton
- **References:** more than 50 units in operation

SIGMA Standard Air Separation Unit

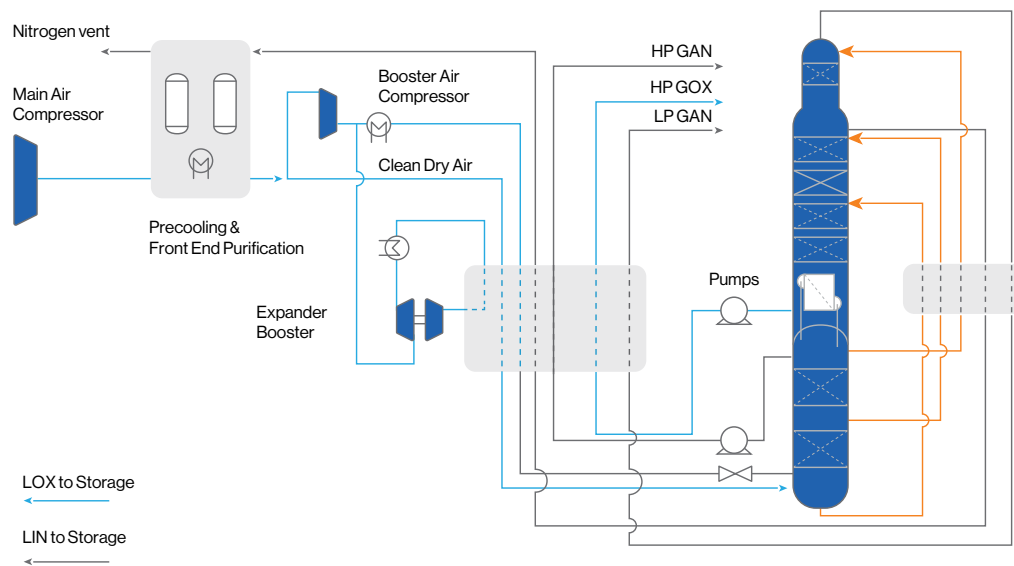

Oxygen generator

Yango™ Standard Air Separation Unit

Oxygen generators for quick-launch projects

The Yango™ standardized air separation unit (ASU) is designed for customers with quick-launch projects, where time to production is a priority. The Yango™ unit combines air compression, adsorption purification, cryogenic distillation of main components, and the internal compression of gases to the pressure required by the end-user. This fully-packaged stand-alone unit produces 99.6 to 99.8 % pure oxygen. Co-products include nitrogen, liquid oxygen, liquid nitrogen, liquid argon, and compressed dry air.

Cost-efficient and flexible

Depending on customer requirements and energy costs, as well as the potential for integration into customer processes, the Yango™ unit can be configured to optimize capital expenditures (CAPEX) and/or operational expenditures (OPEX).

Typical applications

Installed in plants in the steel (e.g. basic oxygen furnaces, blast furnaces, electric arc furnaces), chemicals (e.g. ethylene oxide, ammonia), and oil refining (e.g. desulphurization, gas-to-liquid) industries.

Advantages

- Ideal for quick-launch projects
- Short time to production
- Configured for CAPEX and/or OPEX
- Co-products:
 - Liquid nitrogen
 - Liquid oxygen
 - Liquid argon
 - Gaseous nitrogen
 - Compressed dry air
- Safe, reliable, simple to operate, easy to maintain

Specifications

- **Plant type:** Skid manufactured unit
- **Production capacity:** 330 to 770 tons per day of oxygen
- **Purity:** 99.5% to 99.8% oxygen
- **Pressure:** Up to 42 barg
- **Specific energy:** 400 to 600 Kilowatt hours per ton (kWh/t)
- **References:** more than 20 units in operation

Yango™ Standard Air Separation Unit

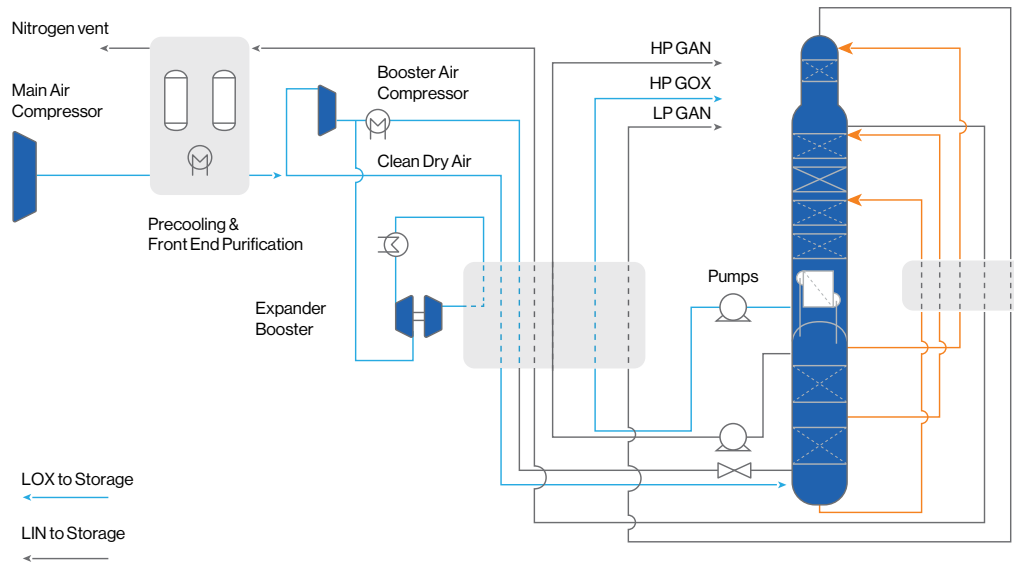

Nitrogen generator

APSA

Nitrogen Generation Unit

Nitrogen generator with multiple models and options

The APSA nitrogen generation unit uses the latest technology, combining air compression, adsorption, purification, and cryogenic distillation of the main components.

Flexible configurations and customization options

The APSA unit is fully packaged, enabling easy plug-and-play installation. Depending on customer requirements, it can be configured to optimize capital expenditures (CAPEX) and/or operational expenditures (OPEX). The unit can also be customized, with options that include:

- back-up vaporizers and storage for increased availability and reliability;
- liquid co-production to refill back-up liquid storage.

Typical applications

Installed in liquefied natural gas (LNG) terminals, electronics plants, and oil refineries (special version meets the most stringent oil industry standards).

Advantages

- Configured for CAPEX and/or OPEX
- Optional co-products:
 - Liquid nitrogen
 - Liquid oxygen
 - Compressed dry air
 - Residual air (enriched in oxygen)
 - Optional back-up vaporizers and storage
- Safe, reliable, simple to operate, easy to maintain
- Plug-and-play installation
- Short construction time

Specifications

- **Plant type:** Skid manufactured unit
- **Production capacity:** 1,000 to 50,000 normal cubic meters per hour of gaseous nitrogen
- **Purity:** down to 1 ppb of oxygen
- **Pressure:** 2 to 10 barg
- **References:** more than 600 units

APSA Nitrogen generation unit

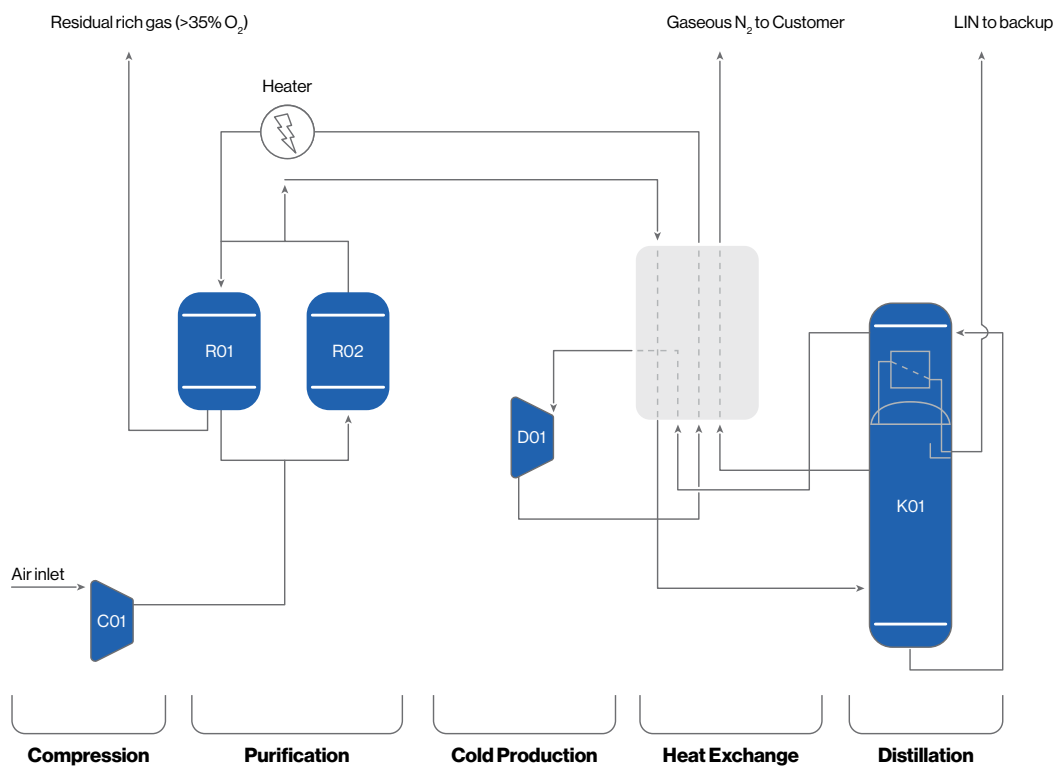

Customer Services

Comprehensive suite of value-added services

We provide Customer Services in four categories – Engineering, Remote Support, On-Site and Spare Parts – providing you with convenient solutions that maximize the efficiency and reliability of your assets.

Customer Service Agreements

Each CSA is a true partnership, providing as many of our services as you require in a single agreement of variable duration.



Building stronger partnerships based on your needs

Our long experience underlies our ability to excel with a wide range of technologies and processes – and the flexibility to adapt to the specifics of your operation – wherever you are located.

We also devote significant resources to meeting Customer expectations. For example, Customer Services draws on Air Liquide Engineering & Construction' research and development work, which benefits from daily operational feedback from installed plants around the world.

Project execution always follows a proven process, from diagnosis to post-deployment feedback. This disciplined approach assures you of the efficient implementation and measurable benefits you deserve.

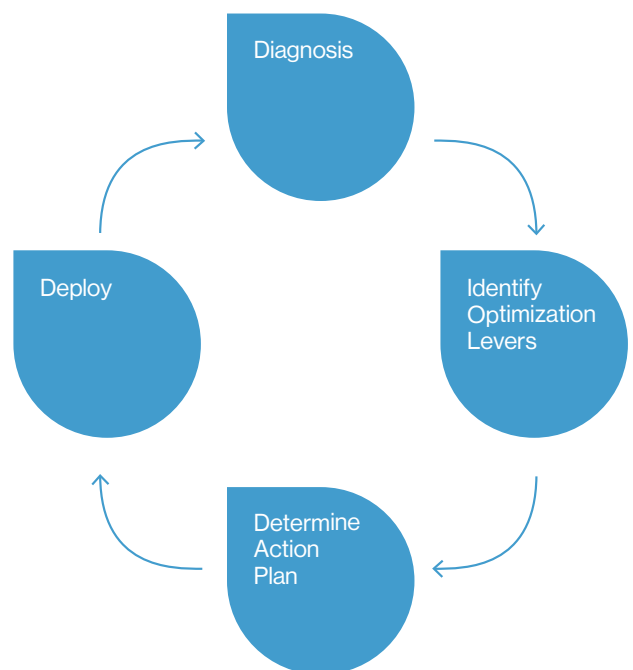

Proprietary technology and beyond

Customizable solutions for the full lifecycle of engineering and construction projects

We provide customers with total support from the beginning to the completion of each project – including the optimization and maintenance of plants in production.

Safety and quality are central to us. Every action we undertake, from initial design through to construction, reflects our goal of ensuring personal safety and protecting the environment while achieving your technical and production goals.

To achieve all this, we maintain an experienced team with multidisciplinary expertise, including:

- process design;
- detailed engineering;
- piping and instrumentation;
- electrical, mechanical and civil engineering.

What truly differentiates our team? The ability to question conventional thinking, and find new solutions, on a continuing basis. More than 1,600 patents we have filed underline the strength of our approach.

A world of expertise on each project

Global network of engineering and manufacturing centers

Air Liquide Engineering & Construction combines technical expertise with innovative technology to help both the Air Liquide Group and customers from many industries to engineer, construct and procure gas processing facilities and the related infrastructure.

Through our global network of engineering and manufacturing centers, we have the resources to work closely with customers and vendors, and offer highly-effective project management, procurement and execution services.

All this enables us to provide you with a world of expertise and experience on each project. As a result you benefit from forward-thinking technology choices, as well as seamless project implementation.





● Engineering Centers and front-end offices ● Manufacturing centers



Contact us

standard-plants@airliquide.com

www.engineering-airliquide.com